



More Precision

confocalDT // Confocal chromatic sensor system



Dimensions
(in mm, not to scale)

IFS2404-2

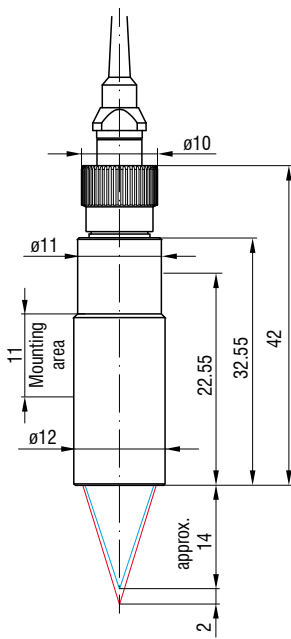

IFS2404/90-2

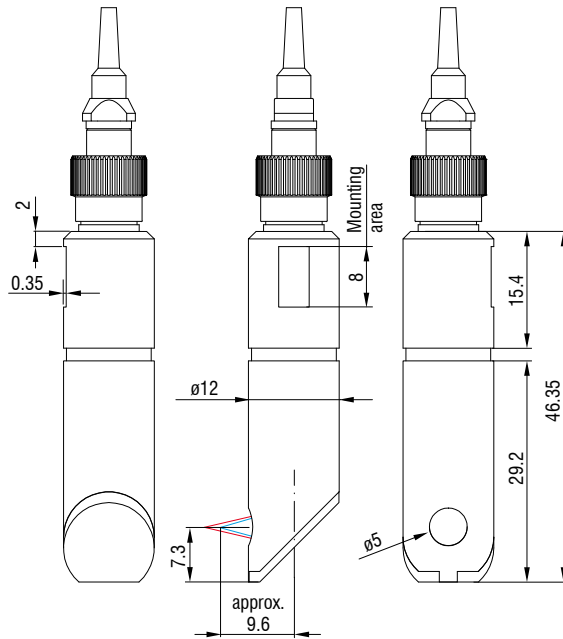

IFS2404-2(001)

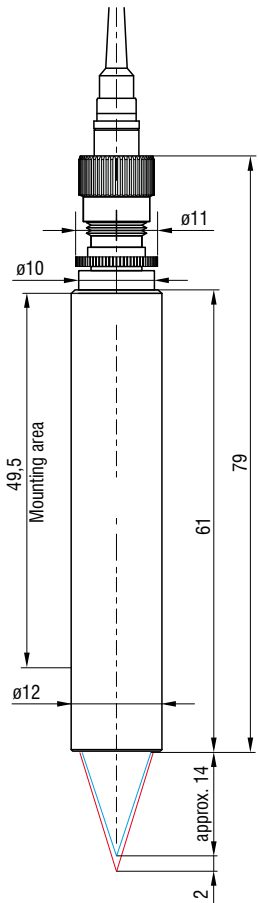

IFS2404/90-2(001)

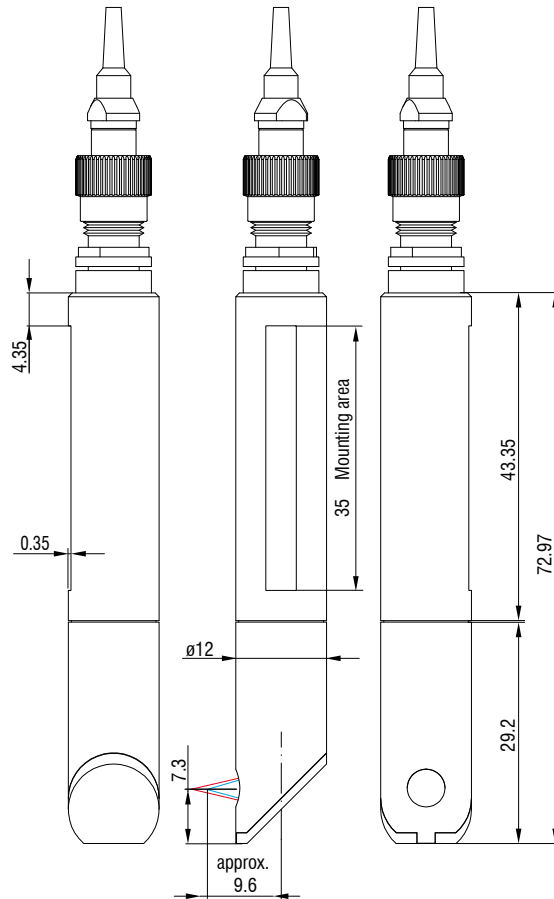



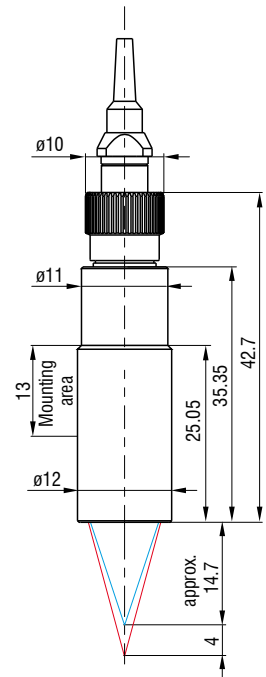

IFS2404-4



Confocal chromatic sensors for series applications

confocalDT IFS2404

-  Submicron resolution
-  For one-sided thickness measurements
-  Suitable for precise distance measurements
-  Small light spot
-  Excellent price-performance ratio

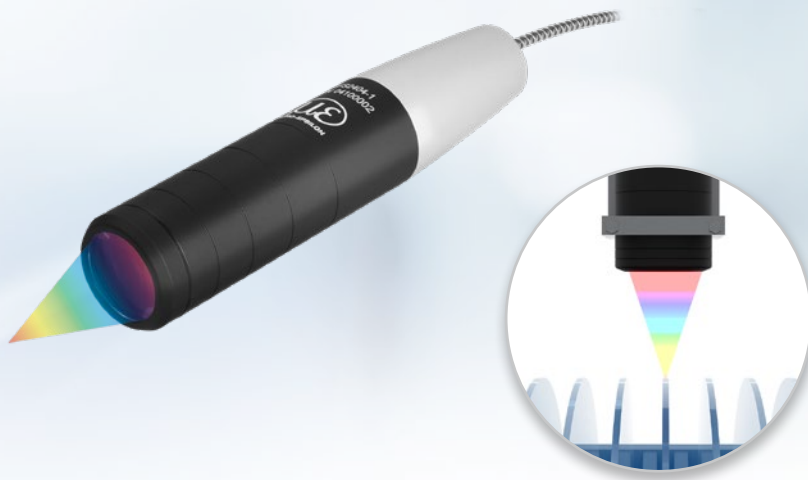

Model		IFS2404-1	IFS2404-3	IFS2404-6	IFS2404-18
Measuring range		1 mm	3 mm	6 mm	18 mm
Start of measuring range	approx.	15 mm	25 mm	35 mm	61 mm
Resolution	Static ^[1]	< 6 nm	< 18 nm	< 40 nm	< 50 nm
	Dynamic ^[2]	< 50 nm	< 125 nm	< 250 nm	< 280 nm
Linearity ^[3]	Displacement and distance	< ±0.25 μm	< ±0.75 μm	< ±1.5 μm	< ±5.4 μm
	Thickness	< ±0.5 μm	< ±1.5 μm	< ±3 μm	< ±10.8 μm
Light spot diameter		12 μm	18 μm	24 μm	50 μm
Maximum measuring angle ^[4]		±25°	±19°	±10°	±9°
Numerical aperture (NA)		0.45	0.35	0.18	0.17
Min. target thickness ^[5]		0.05 mm	0.15 mm	0.3 mm	0.9 mm
Target material		reflective, diffuse as well as transparent surfaces (e.g. glass)			
Connection		pluggable optical fiber via FC socket; for cable type and cable length, see accessories			
Mounting		Radial clamping (mounting adapter see accessories)			
Temperature range	Storage	-20 ... +70 °C			
	Operation	5 ... 70 °C			
Shock (DIN EN 60068-2-27)		15 g/ 6 ms in XY axis, 1000 shocks each			
Vibration (DIN EN 60068-2-6)		2g/ 20 ... 500 Hz on XY axis, 10 cycles each			
Protection class (DIN EN 60529)		IP64 (front)			
Material		Aluminum housing, glass lenses			
Weight ^[6]		approx. 100 g	approx. 100 g	approx. 100 g	approx. 150 g

^[1] Average from 2,048 values at 1 kHz, in the mid of the measuring range onto optical flat

^[2] RMS noise relates to mid of measuring range (1 kHz)

^[3] All data at constant ambient temperature (25±1 °C). Measurement on plane-parallel test glass. Acceptance report is enclosed with delivery

^[4] Maximum sensor measuring angle up to which a usable signal can be achieved on reflective surfaces, with accuracy decreasing toward the limit values

^[5] Glass sheet with refractive index n = 1.5 throughout the entire measuring range. In the mid of the measuring range, also thinner layers can be measured.

^[6] Sensor weight without optical fiber

Dimensions

(in mm, not to scale)

IFS2404-1

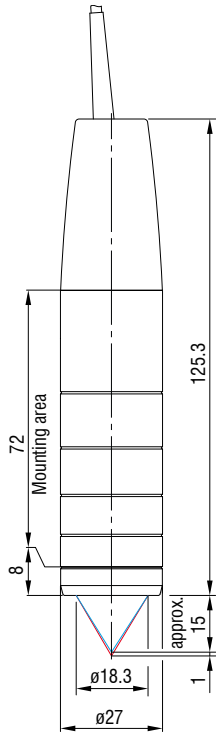

IFS2404-18

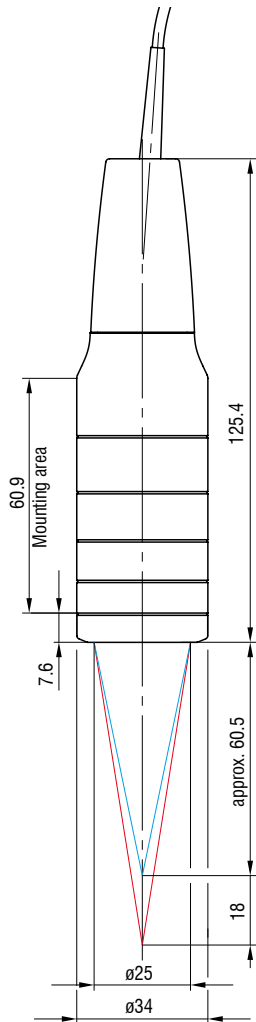

IFS2404-3

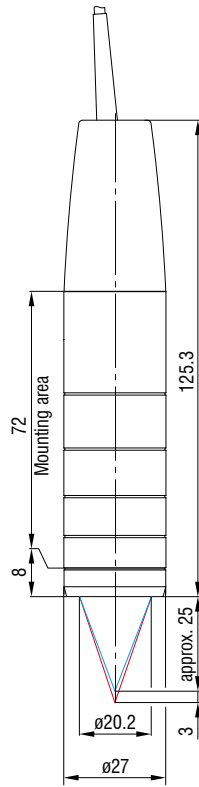



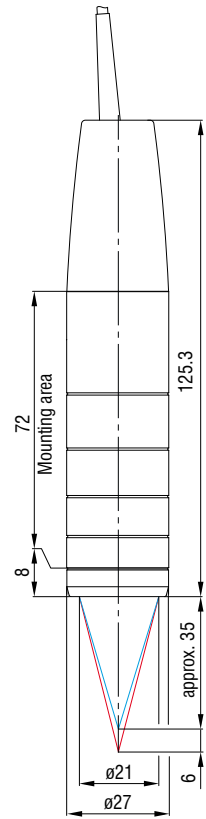



IFS2404-6



High precision sensors for displacement and thickness measurements

confocalDT IFS2407

-  Compact sensors from $\varnothing 12$ mm
-  Submicron resolution
-  For one-sided thickness measurements
-  Suitable for precise distance measurements
-  Very small light spot
-  Large tilt angle

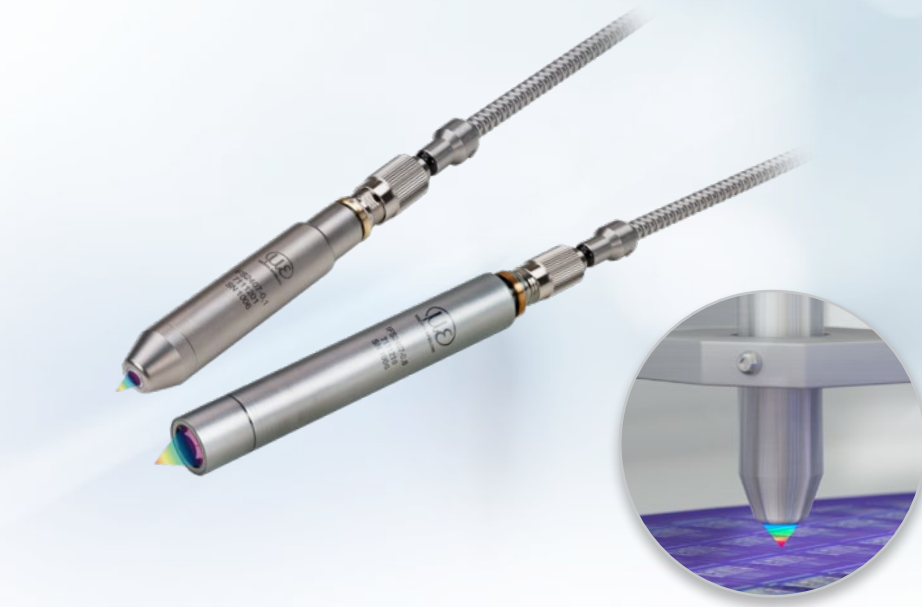

Model		IFS2407-0.1	IFS2407-0.1(001)	IFS2407-0.8
Measuring range		0.1 mm	0.1 mm	0.8 mm
Start of measuring range	approx.	1 mm	1 mm	5.9 mm
Resolution	Static ^[1]	< 1 nm	< 1 nm	< 9 nm
	Dynamic ^[2]	< 6 nm	< 6 nm	< 75 nm
Linearity ^[3]	Displacement and distance	< $\pm 0.04 \mu\text{m}$	< $\pm 0.04 \mu\text{m}$	< $\pm 0.2 \mu\text{m}$
	Thickness	-	-	< $\pm 0.4 \mu\text{m}$
Light spot diameter		3 μm	4 μm	6 μm
Maximum measuring angle ^[4]		$\pm 48^\circ$	$\pm 48^\circ$	$\pm 30^\circ$
Numerical aperture (NA)		0.80	0.70	0.50
Min. target thickness ^[5]		0.005 mm	0.005 mm	0.04 mm
Target material		reflective, diffuse as well as transparent surfaces (e.g. glass)		
Connection		pluggable optical fiber via FC socket; for cable type and cable length, see accessories		
Mounting		Radial clamping (mounting adapter see accessories)		
Temperature range	Storage	-20 °C ... +70 °C		
	Operation	+5 °C ... +70 °C		
Shock (DIN EN 60068-2-27)		15 g / 6 ms in XY axis, 1000 shocks each		
Vibration (DIN EN 60068-2-6)		2 g/ 20 ... 500 Hz in XY axis, 10 cycles each		
Protection class (DIN EN 60529)		IP65 (front)		
Material		Stainless steel housing, glass lenses		
Weight ^[6]		approx. 36 g	approx. 36 g	approx. 40 g
Special features		Sensor with high numerical aperture	Light-intensive sensor	-

^[1] Average from 2,048 values at 1 kHz, in the mid of the measuring range onto optical flat

^[2] RMS noise relates to mid of measuring range (1 kHz)

^[3] All data at constant ambient temperature (25 \pm 1 °C). Measurement on plane-parallel test glass. Acceptance report is enclosed with delivery

^[4] Maximum sensor measuring angle up to which a usable signal can be achieved on reflective surfaces, with accuracy decreasing toward the limit values

^[5] Glass sheet with refractive index $n = 1.5$ throughout the entire measuring range. In the mid of the measuring range, also thinner layers can be measured.

^[6] Sensor weight without optical fiber

Dimensions
(in mm, not to scale)

IFS2407-0.1
IFS2407-0.1(001)

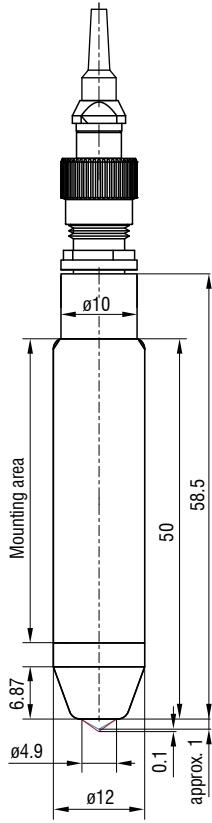



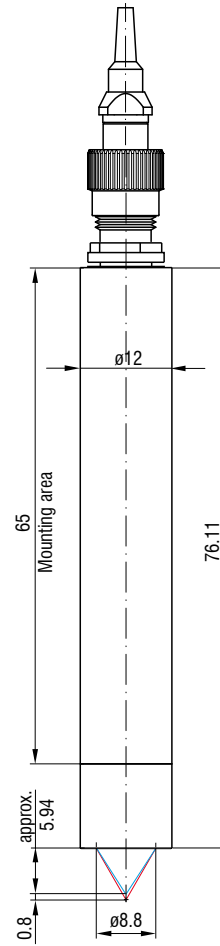



IFS2407-0.8



High precision sensors for displacement and thickness measurements

confocalDT IFS2407

-  Compact sensors from $\varnothing 12$ mm
-  Submicron resolution
-  For one-sided thickness measurements
-  Suitable for precise distance measurements
-  Very small light spot
-  Large tilt angle



Model		IFS2407/90-0.3	IFS2407-1.5	IFS2407-3	IFS2407-6
Measuring range		0.3 mm	1.5 mm	3 mm	6 mm
Start of measuring range	approx.	5.3 mm	17 mm	28 mm	32 mm
Resolution	Static ^[1]	< 3 nm	< 3 nm	< 7 nm	< 8 nm
	Dynamic ^[2]	< 20 nm	< 36 nm	< 63 nm	< 90 nm
Linearity ^[3]	Displacement and distance	< $\pm 0.10 \mu\text{m}$	< $\pm 0.16 \mu\text{m}$	< $\pm 0.45 \mu\text{m}$	$\leq \pm 0.9 \mu\text{m}$
	Thickness	< $\pm 0.20 \mu\text{m}$	< $\pm 0.4 \mu\text{m}$	< $\pm 0.9 \mu\text{m}$	$\leq \pm 1.8 \mu\text{m}$
Light spot diameter		6 μm	5.5 μm	9 μm	14 μm
Maximum measuring angle ^[4]		$\pm 27^\circ$	$\pm 43^\circ (\pm 70^\circ)$ ^[5]	$\pm 30^\circ$	$\pm 23^\circ$
Numerical aperture (NA)		0.50	0.70	0.53	0.45
Min. target thickness ^[6]		0.015 mm	0.075 mm	0.15 mm	0.3 mm
Target material		reflective, diffuse as well as transparent surfaces (e.g. glass)			
Connection		pluggable optical fiber via FC socket; for cable type and cable length, see accessories			
Mounting		Mounting holes (2x M2)	Radial clamping (mounting adapter see accessories)		
Temperature range	Storage	-20 °C... +70 °C			
	Operation	+5 °C... +70 °C			
Shock (DIN EN 60068-2-27)		15 g / 6 ms in XY axis, 1000 shocks each			
Vibration (DIN EN 60068-2-6)		2 g / 20 ... 500 Hz in XY axis, 10 cycles each			
Protection class (DIN EN 60529)		IP65 (front)			
Material		Stainless steel housing, glass lenses		Aluminum housing, glass lenses	
Weight ^[7]		approx. 30 g	approx. 800 g	approx. 550 g	approx. 350 g

^[1] Average from 2,048 values at 1 kHz, in the mid of the measuring range onto optical flat

^[2] RMS noise relates to mid of measuring range (1 kHz)

^[3] All data at constant ambient temperature (25 ± 1 °C). Measurement on plane-parallel test glass. Acceptance report is enclosed with delivery

^[4] Maximum sensor measuring angle up to which a usable signal can be achieved on reflective surfaces, with accuracy decreasing toward the limit values

^[5] Maximum sensor measuring angle up to which a usable signal can be achieved on diffusely reflecting metallic surfaces, with accuracy decreasing toward the limit values

^[6] Glass sheet with refractive index $n = 1.5$ throughout the entire measuring range. In the mid of the measuring range, also thinner layers can be measured.

^[7] Sensor weight without optical fiber

Dimensions
(in mm, not to scale)

IFS2407/90-0,3

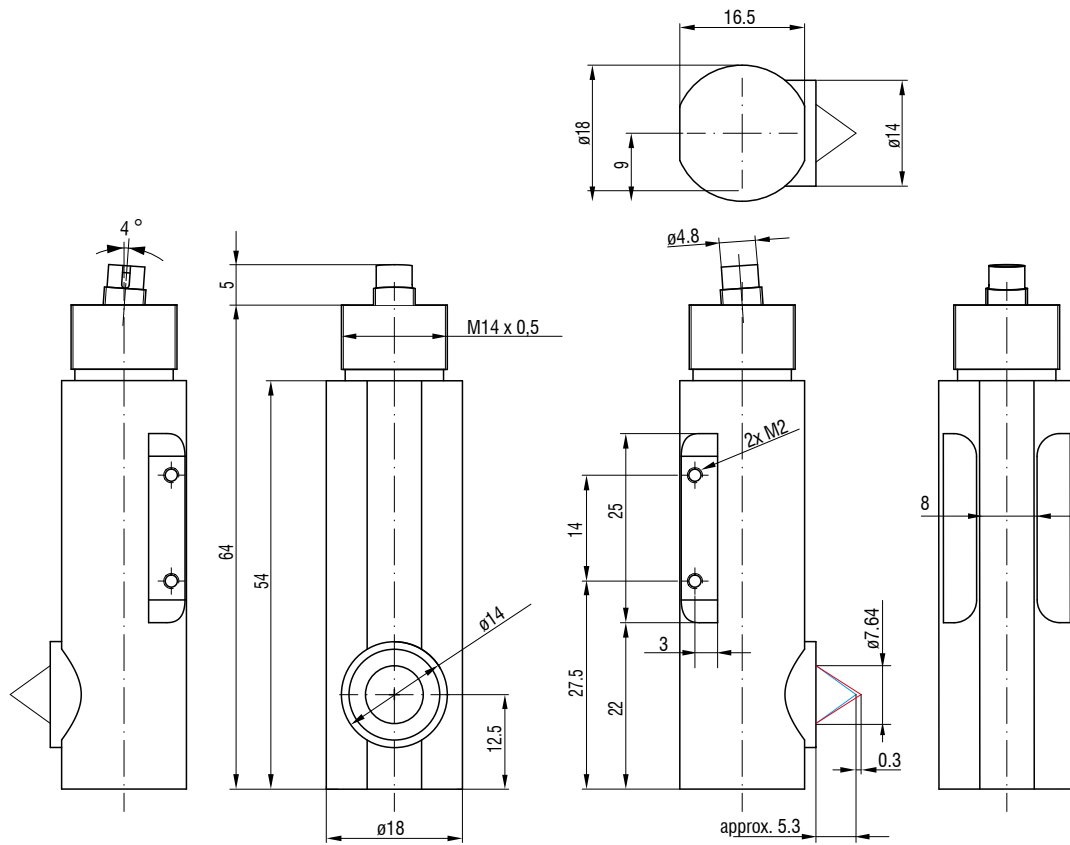

IFS2407-1,5

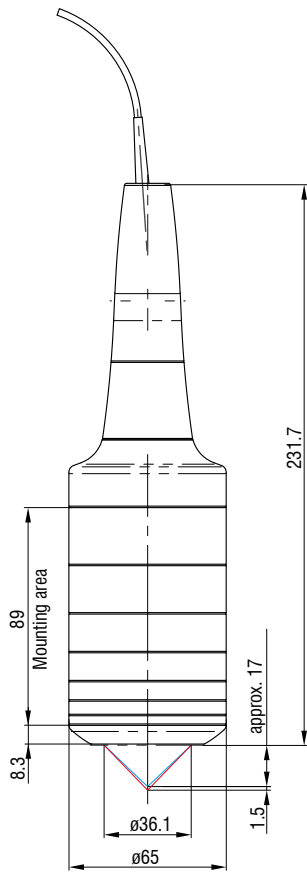

IFS2407-3

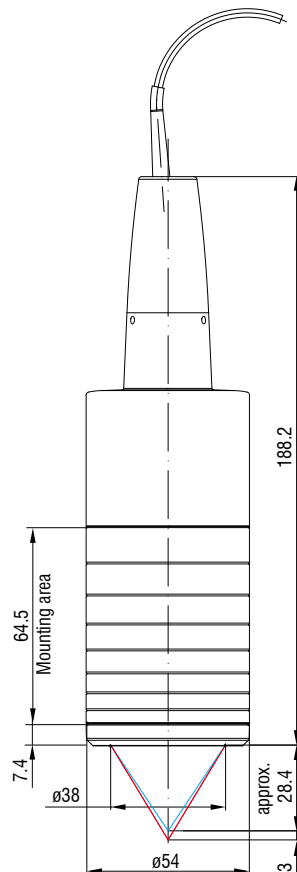

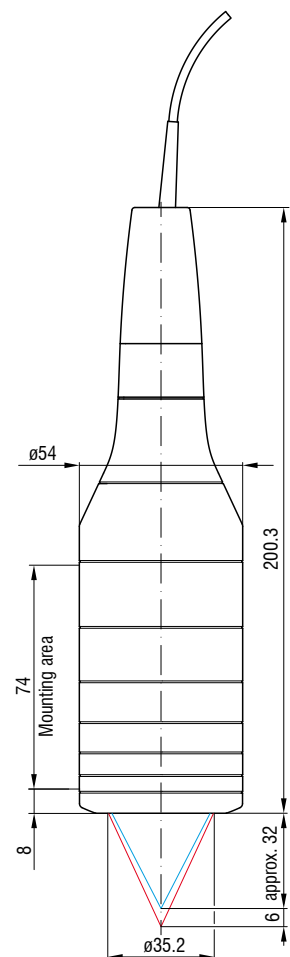

IFS2407-6



Compact confocal chromatic controllers for industrial series applications

confocalDT IFC2411 / IFC2412

-  Most compact confocal controller on the market
-  Nanometer resolution for precise distance and thickness measurements
- INTERFACE** Flexible integration via Ethernet, RS422 or analog output (U/I)
-  Direct PLC connection due to Industrial Ethernet
- IP40** Robust aluminum housing (IP40)
- Best price** Excellent price-performance ratio



Powerful confocal chromatic controllers

The IFC2411 and IFC2412 controllers set new standards in non-contact distance and thickness measurements. The most compact confocal chromatic controllers currently available deliver impressive results with high-precision measurements at high speeds. Their unique design makes these controllers ideal for easy integration into existing plants and systems. They can be quickly mounted on a DIN rail and fit into even the smallest control cabinets.

One controller – two channels with full performance

With the dual-channel version confocalDT IFC2412, integrated calculation functions enable the data combination of both channels, for example for thickness measurements of battery film. The measured values are recorded synchronously and at full measuring rate for both channels.

Maximum sensor variety, numerous application options

The flexible connection of various sensors enables measurements on almost all surfaces as well as one-sided thickness measurements on transparent objects. Micro-Epsilon's extensive sensor portfolio covers measuring ranges from 0.1 mm to 30 mm. In addition, the sensors are available for use in high-temperature environments and in a vacuum.

Developed for industrial production, OEMs and automation

Diverse interfaces enable flexible integration into machines and systems. The robust IP40 aluminum housing provides reliable protection in industrial environments for maximum precision and signal stability. These systems impress in series and OEM applications with their outstanding performance and excellent price-performance ratio.

Video signal display

Measurement chart

Presets for fast setting

Simple operation via web interface

Setup and configuration of the controller and sensors are handled in a user-friendly web interface via Ethernet connection. No additional software is required. For thickness measurements, materials are stored in an editable materials database.

Model		IFC2411	IFC2411/IE
Resolution	Ethernet	1 nm	-
	Industrial Ethernet	-	1 nm
	RS422	18 bit	
	Analog	16 bits (teachable)	
Measuring rate	Continuously adjustable from 100 Hz to 8 kHz		
Linearity ^[1]	typ. < ±0.02 % FSO (depends on sensor)		
Multi-peak measurement	1 layer		
Light source	Internal white LED		
No. of characteristic curves	up to 10 characteristic curves for different sensors per channel, selection via table in the menu		
Permissible extraneous light ^[2]	30.000 lx		
Synchronization	yes		
Supply voltage	24 VDC ± 10 %		
Power consumption	< 7 W (24V)		
Signal input	sync-in / trig-in; 1x encoder (A+, A-, B+, B-, index)		
Digital interface ^[3]	Ethernet / RS422		EtherCAT / PROFINET / Ethernet/IP / RS422
Analog output	Current: 4 ... 20 mA; voltage: 0 ... 5V & 0 ... 10 V (16 bit D/A converter)		
Digital output	Sync-out		
Connection	Optical	pluggable optical fiber via E2000 socket, length 2 m ... 50 m, min. bending radius 30 mm	
	Electrical	3-pin supply terminal block; 6-pin I/O terminal block (max. cable length 30 m); 17-pin M12 connector for RS422, analog and encoder; RJ45 connector for Ethernet (max. cable length 100 m)	3-pin supply terminal block; 5-pin I/O terminal block (max. cable length 30 m); 17-pin M12 connector for RS422, analog and encoder; RJ45 connector for Industrial Ethernet (max. cable length 100 m)
Mounting	free-standing, DIN rail mounting		
Temperature range	Storage	-20 ... +70 °C	
	Operation	+5 ... +50 °C	
Shock (DIN EN 60068-2-27)	15 g/6 ms on XYZ axis, 1000 shocks each		
Vibration (DIN EN 60068-2-6)	2 g / 20 ... 500 Hz in XYZ axis, 10 cycles each		
Protection class (DIN EN 60529)	IP40		
Material	Aluminum		
Weight	approx. 335 g		
Compatibility	compatible with all confocalDT sensors		
No. of measurement channels	1		
Control and indicator elements	Web interface for setup and settings; Multifunction button: interface selection, adjustable functions and reset to factory settings after 10 s; 4x color LEDs for intensity, range, link and data		Web interface for setup and settings; Multifunction button: interface selection, adjustable functions and reset to factory settings after 10 s; 4x color LEDs for Intensity, Range, RUN and ERR

^[1] FSO = Full Scale Output

^[2] Illuminant: light bulb

^[3] The controller can also be parameterized via Ethernet

Compact confocal chromatic controllers for industrial series applications

confocalDT IFC2411 / IFC2412

Model		IFC2412	IFC2412/IE
Resolution	Ethernet	1 nm	-
	Industrial Ethernet	-	1 nm
	RS422	18 bit	18 bit
	Analog	16 bits (teachable)	16 bits (teachable)
Measuring rate	Continuously adjustable from 100 Hz to 8 kHz		
Linearity ^[1]	typ. < ±0.02 % FSO (depends on sensor)		
Multi-peak measurement	1 layer		
Light source	Internal white LED		
No. of characteristic curves	Storage of up to 10 characteristic curves for different sensors per channel, selection via table in the menu		
Permissible ambient light ^[2]	30.000 lx		
Synchronization	yes		
Supply voltage	24 VDC ± 10 %		
Power consumption	< 9 W (24V)		
Signal input	Sync-In / trig-In; 2 encoders (A+, A-, B+, B-, Index) 3 encoders (A+, A-, B+, B-)		
Digital interface	Ethernet / RS422		EtherCAT / RS422
Analog output	2x freely selectable (16 bit D/A converter) Current: 4 ... 20 mA; voltage: 0 ... 5 V & 0 ... 10 V		
Digital output	Sync-out		
Connection	Optical	pluggable optical fiber via E2000 socket, length 2 m ... 50 m, min. bending radius 30 mm	
	Electrical	3-pin supply terminal block; 5-pin terminal for Out/Trig; 6-pin I/O terminal block (max. cable length 30 m); 17-pin M12 connector for RS422, analog and encoder; RJ45 connector for Ethernet) (max. cable length 100 m)	
Mounting	free-standing, DIN rail mounting		
Temperature range	Storage	-20 ... +70 °C	
	Operation	+5 ... +50 °C	
Shock (DIN EN 60068-2-27)	15 g/6 ms on XYZ axis, 1000 shocks each		
Vibration (DIN EN 60068-2-6)	2 g / 20 ... 500 Hz in XYZ axis, 10 cycles each		
Protection class (DIN EN 60529)	IP40		
Material	Aluminum		
Weight	670 g		670 g
Compatibility	compatible with all confocalDT sensors		
No. of measurement channels	2		2
Control and indicator elements	Web interface for setup and settings; Multifunction button: interface selection, adjustable functions and reset to factory settings after 10 s; 4x color LEDs for intensity, range, link and data		Web interface for setup and settings; Multifunction button: interface selection, adjustable functions and reset to factory settings after 10 s; 4x color LEDs for Intensity, Range, RUN and ERR

^[1] FSO = Full Scale Output

^[2] Illuminant: light bulb

Dimensions

(in mm, not to scale)

confocalDT IFC2411

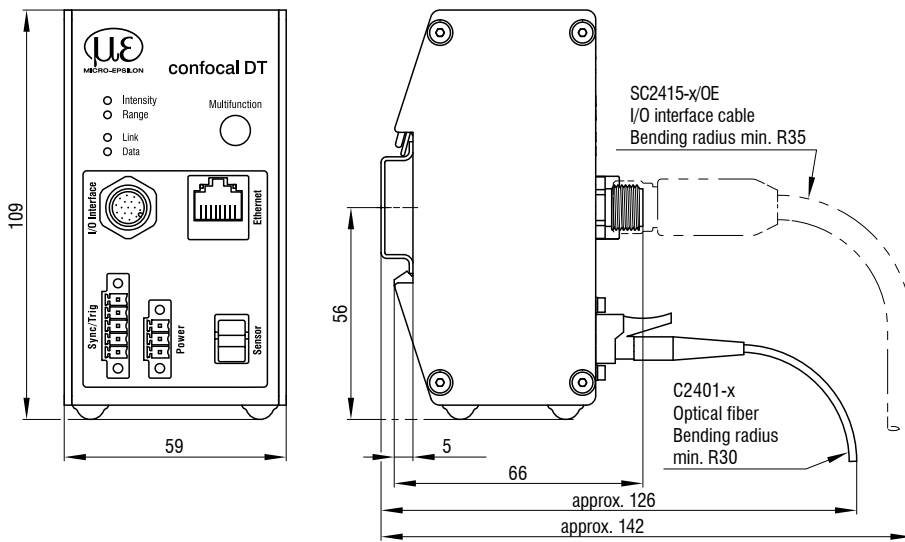



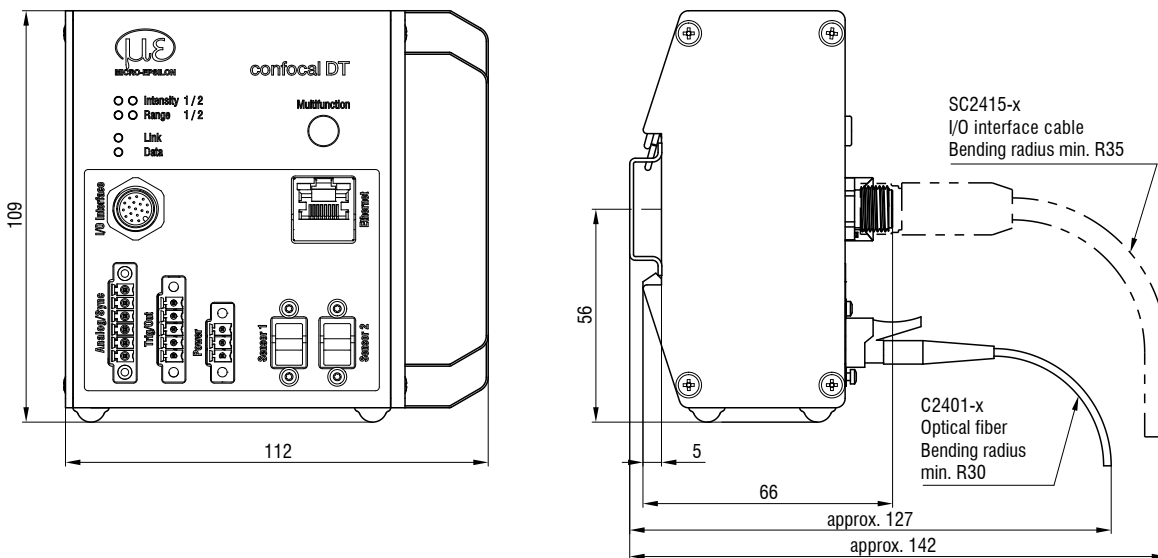



confocalDT IFC2412



Compact confocal controllers for precise and fast inline processes

confocalDT IFC2416 / IFC2417

-  Nanometer resolution for highest precision
-  Ideal for extremely fast distance and thickness measurements up to 25 kHz
-  Multi-peak: up to 5 layers with one measurement
-  Best signal quality and stability due to high light intensity
-  Flexible integration via Ethernet, RS422 or analog output
-  Compact design and robust IP40 aluminum housing

25 kHz
Measuring rate

IFS240x
Sensor compatibility

IP40
Protection

5 layers
Multi-layer measurement



Compact housing – maximum speed & precision

The confocal chromatic controllers IFC2416 and IFC2417 feature a high measuring rate of 25 kHz and enormous light intensity. This enables stable and precise measurements at high speed on various materials and surfaces.

These compact controllers are used for high-resolution distance and thickness measurements in all areas of industry. Thanks to the multi-peak option, multi-layer measurements of transparent objects with up to 5 layers are possible.

One controller – two channels with full performance

With the dual-channel version confocalDT IFC2417, integrated calculation functions enable the data combination of both channels, for example for thickness measurements of battery film. The measured values are recorded synchronously and at full measuring rate for both channels.

Flexible choice of sensor for a wide range of applications

The flexible connection of various sensors enables measurements on almost all surfaces as well as one-sided thickness measurements on transparent objects. Micro-Epsilon's extensive sensor portfolio covers measuring ranges from 0.1 mm to 30 mm. In addition, sensors are available for use in high-temperature environments and in a vacuum.

Robustness and ease of integration

The powerful controllers are optimally protected in a compact IP40 aluminum housing for easy integration into machines and production lines. Several interfaces are available for integration purposes. In addition to Ethernet and RS422, analog signals can be output as current or voltage values. In addition, encoder inputs as well as a synchronization and switching output support optimal process control.



Extremely high light intensity
Stable and fast measurements on all materials and surfaces

Largest sensor portfolio
Flexible selection of

- Measuring range & offset distance
- Field of application: vacuum, industry, temperature
- Light spot & measuring angle
- Design & beam path (straight/lateral)



One-sided thickness measurements,
e.g. of flat glass



Structured surfaces,
e.g. metals



Dark surfaces,
e.g. rubber

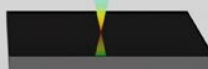

Shiny surfaces,
e.g. mirrors



Detection of fine structures,
e.g. PCB traces

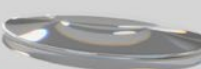

Optical glasses,
e.g. lenses

Model		IFC2416
Resolution	Ethernet	1 nm
	RS422	18 bit
	Analog	16 bits (teachable)
Measuring rate	Continuously adjustable from 100 Hz to 25 kHz	
Linearity ^[1]	typ. < ±0.02 % FSO (depends on sensor)	
Multi-peak measurement	5 layers	
Light source	Internal white LED	
No. of characteristic curves	up to 10 characteristic curves for different sensors per channel, selection via table in the menu	
Permissible ambient light ^[2]	30.000 lx	
Synchronization	yes	
Supply voltage	24 VDC ±10 %	
Power consumption	< 9 W (24V)	
Signal input	Sync-In / trig-In; 2 encoders (A+, A-, B+, B-, Index) 3 encoders (A+, A-, B+, B-)	
Digital interface	Ethernet / RS422	
Analog output	Current: 4 ... 20 mA; voltage: 0 ... 5V & 0 ... 10 V (16 bit D/A converter)	
Digital output	Sync-out; error-out	
Connection	Optical	pluggable optical fiber via E2000 socket, length 2 m ... 50 m, min. bending radius 30 mm
	Electrical	3-pin supply terminal block; 6-pin I/O terminal block (max. cable length 30 m); 17-pin M12 connector for RS422, analog and encoder; RJ45 connector for Ethernet) (max. cable length 100 m)
Mounting	free-standing, DIN rail mounting	
Temperature range	Storage	-20 ... +70 °C
	Operation	+5 ... +50 °C
Shock (DIN EN 60068-2-27)	15 g/6 ms on XYZ axis, 1000 shocks each	
Vibration (DIN EN 60068-2-6)	2 g / 20 ... 500 Hz in XYZ axis, 10 cycles each	
Protection class (DIN EN 60529)	IP40	
Material	Aluminum	
Weight	approx. 460 g	
Compatibility	compatible with all confocalDT sensors	
No. of measurement channels	1	
Control and indicator elements	Web interface for setup and settings; Multifunction button: interface selection, adjustable functions and reset to factory settings after 10 s; 4x color LEDs for intensity, range, link and data	

^[1] FSO = Full Scale Output

^[2] Illuminant: light bulb

Compact confocal controllers for precise and fast inline processes

confocalDT IFC2416 / IFC2417

Model		IFC2417	IFC2417/IE
Resolution	Ethernet	1 nm	-
	Industrial Ethernet	-	1 nm
	RS422	18 bit	18 bit
	Analog	16 bits (teachable)	16 bits (teachable)
Measuring rate	Continuously adjustable from 100 Hz to 25 kHz		
Linearity ^[1]	typ. < ±0.02 % FSO (depends on sensor)		
Multi-peak measurement	5 layers		
Light source	Internal white LED		
No. of characteristic curves	Storage of up to 10 characteristic curves for different sensors per channel, selection via table in the menu		
Permissible ambient light ^[2]	30.000 lx		
Synchronization	yes		
Supply voltage	24 VDC ±10 %		
Power consumption	< 12 W (24V)		
Signal input	Sync-In / trig-In; 2 encoders (A+, A-, B+, B-, Index) 3 encoders (A+, A-, B+, B-)		
Digital interface	Ethernet / RS422		EtherCAT / RS422
Analog output	2x freely selectable (16 bit D/A converter) Current: 4 ... 20 mA; voltage: 0 ... 5 V & 0 ... 10 V		
Digital output	Sync-out; error-out		
Connection	Optical	pluggable optical fiber via E2000 socket, length 2 m ... 50 m, min. bending radius 30 mm	
	Electrical	3-pin supply terminal block; 5-pin terminal for Out/Trig; 6-pin I/O terminal block (max. cable length 30 m); 17-pin M12 connector for RS422, analog and encoder; RJ45 connector for Ethernet) (max. cable length 100 m)	
Mounting	free-standing, DIN rail mounting		
Temperature range	Storage	-20 ... +70 °C	
	Operation	+5 ... +50 °C	
Shock (DIN EN 60068-2-27)	15 g/6 ms on XYZ axis, 1000 shocks each		
Vibration (DIN EN 60068-2-6)	2 g / 20 ... 500 Hz in XYZ axis, 10 cycles each		
Protection class (DIN EN 60529)	IP40		
Material	Aluminum		
Weight	670 g	670 g	
Compatibility	compatible with all confocalDT sensors		
No. of measurement channels	2	2	
Control and indicator elements	Web interface for setup and settings; Multifunction button: interface selection, adjustable functions and reset to factory settings after 10 s; 4x color LEDs for intensity, range, link and data		

^[1] FSO = Full Scale Output

^[2] Illuminant: light bulb

Dimensions

(in mm, not to scale)

confocalDT IFC2416

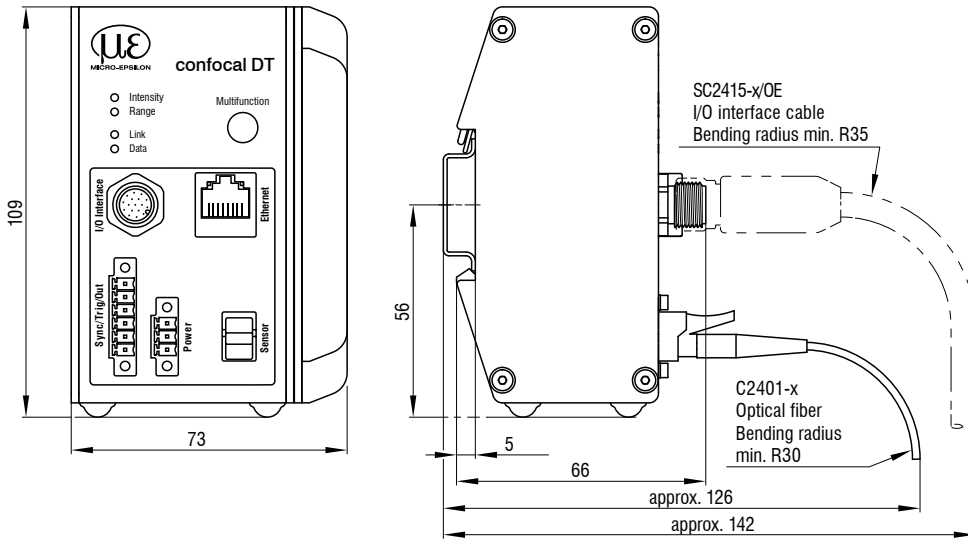

confocalDT IFC2417

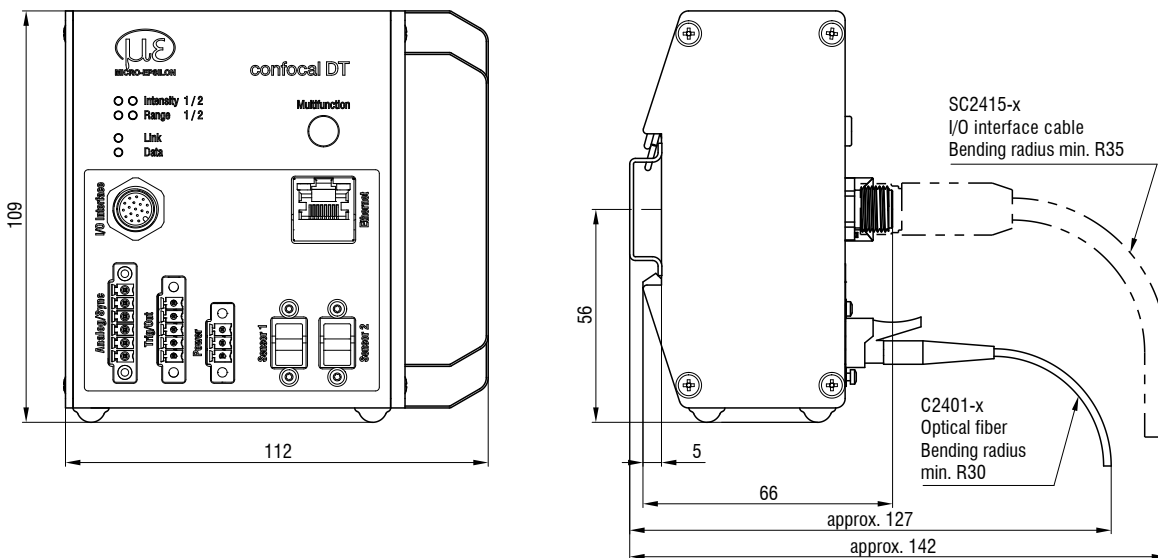

Sensors and Systems from Micro-Epsilon



Sensors and systems for displacement, distance and position



Sensors and measurement devices for non-contact temperature measurement

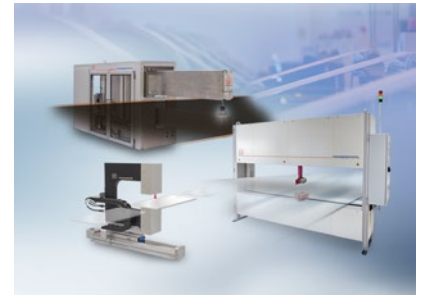

Measuring and inspection systems for metal strips, plastics and rubber



Optical micrometers and fiber optics, measuring and test amplifiers



Color recognition sensors, LED analyzers and inline color spectrometers

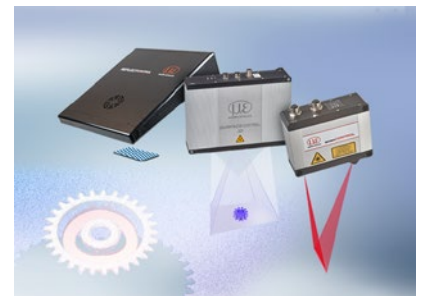

3D measurement technology for dimensional testing and surface inspection