

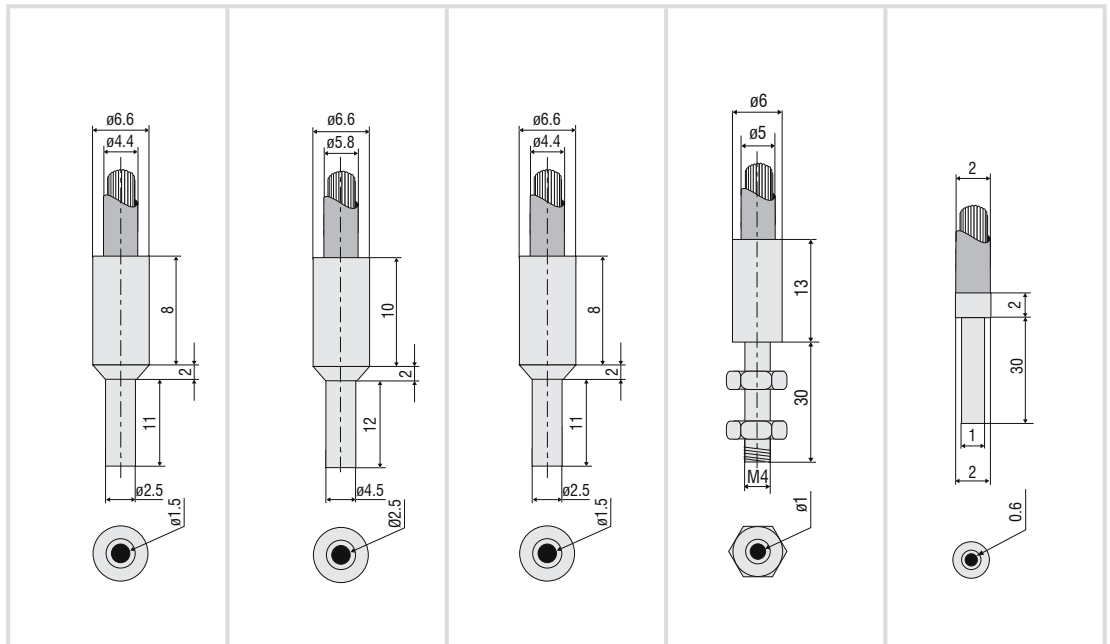

More Precision

opto**CONTROL** CLS1000 // Fiber optic sensor for industrial applications





Model	CFS4-A11	CFS4-A20	CFS4-A30	CFS4-C10-M	CFS4-B11-P	
Article number	10810487	10810351	10810584	10810383	10810254	
Sensor type	Reflex sensor					
Detection range ¹⁾	Start	1 mm	1 mm	1 mm	1 mm	
	End	132 mm	394 mm	430 mm	50 mm	19 mm
Measurement geometry	0°:0°					
Connection	Screwable fiber optic cable via FA socket (M18x1), standard length 1.2 m					
	max. bending radius 13.2 mm	max. bending radius 17.4 mm	max. bending radius 22.5 mm	max. bending radius 13.2 mm	max. bending radius 6 mm	
Mounting	FA (M18x1)					
Temperature range	Storage	Sensor head: -10 ... +80 °C; Fiber optic cable: -60 ... +180 °C			Sensor head: -10 ... +80 °C	Sensor head: -10 ... +80 °C;
	Operation				Fiber optic cable: -40 ... +300 °C	Fiber optic cable: -20 ... +80 °C
Humidity (non-condensing)	20 ... 80 % RH			20 ... 60 % RH	20 ... 80 % RH	
Protection class (DIN EN 60529)	IP64			IP40	IP64	
Sensor head	Stainless steel					
Material	Optical fibers	integrated glass fiber (Ø1.5 mm) and metal-silicone coating (T)		integrated glass fiber (Ø3.0 mm) and metal-silicone (T) sheathing	integrated glass fiber (Ø1.0 mm) and metal (M) sheathing	integrated glass fiber (Ø0.6 mm) and PVC plastic (P) sheathing
		Weight	50 g	90 g	114 g	60 g
Compatibility	compatible with all CLS and CFO controllers					
Special features	All variants are also available with different sheath, length 0.3 ... 10 m, vibration protection, IP protection, suitable for drag chains and available for temperature ranges up to 2000 °C. In combination with a pressure-tight feedthrough, a stainless steel sheath and T250° bonding, vacuum applications down to 10 ⁻⁵ mbar are also possible.					

¹⁾ Detection range refers to polished stainless steel.

Sensors and Systems from Micro-Epsilon



Sensors and systems for displacement, distance and position



Sensors and measurement devices for non-contact temperature measurement

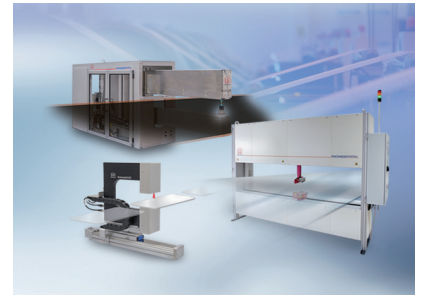

Measuring and inspection systems for metal strips, plastics and rubber



Optical micrometers and fiber optics, measuring and test amplifiers



Color recognition sensors, LED analyzers and inline color spectrometers

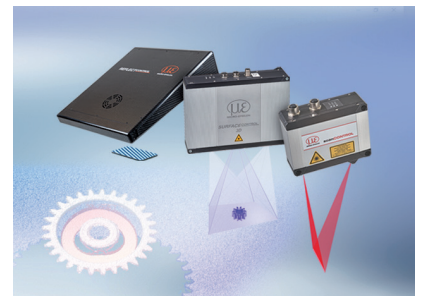

3D measurement technology for dimensional testing and surface inspection