



More Precision

optoNCDT // Laser displacement sensors (triangulation)



Dimensions

optoNCDT 2300

optoNCDT 2300 / Measuring range 2 - 100

optoNCDT 2300-2 ... 2300-100

Diffuse reflection

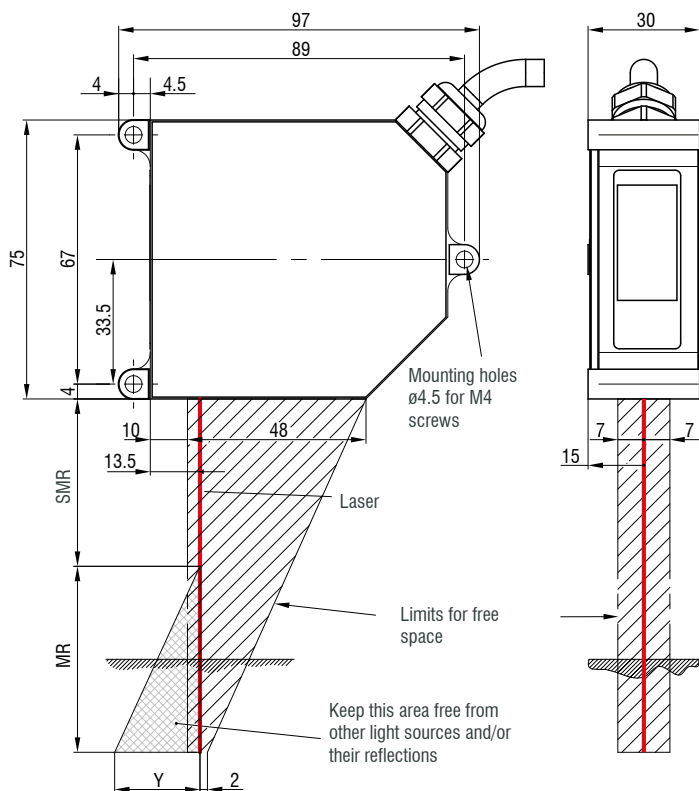

optoNCDT 2300-2 ... 2300-20

Direct reflection

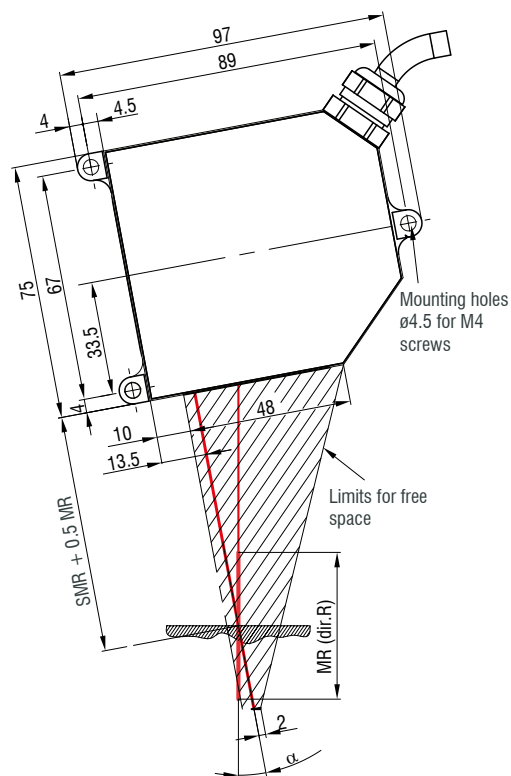

optoNCDT 2300 (Diffuse reflection)
 optoNCDT 2300LL
 optoNCDT 2300BL (Diffuse reflection)

MR	SMR	Y
2	24	1.5
5	24	3.5
10	30	6.5
20	40	10.0
50	45	23.0
100	70	33.5

optoNCDT 2300 (Direct reflection)
 optoNCDT 2300BL (Direct reflection)

MR	SMR + 0.5 MR	α
2	25	20.5 °
5	26.5	20 °
10	35	17.5 °
20	50	13.8 °

Connector (sensor side)



optoNCDT 2300 / Measuring ranges 200/300

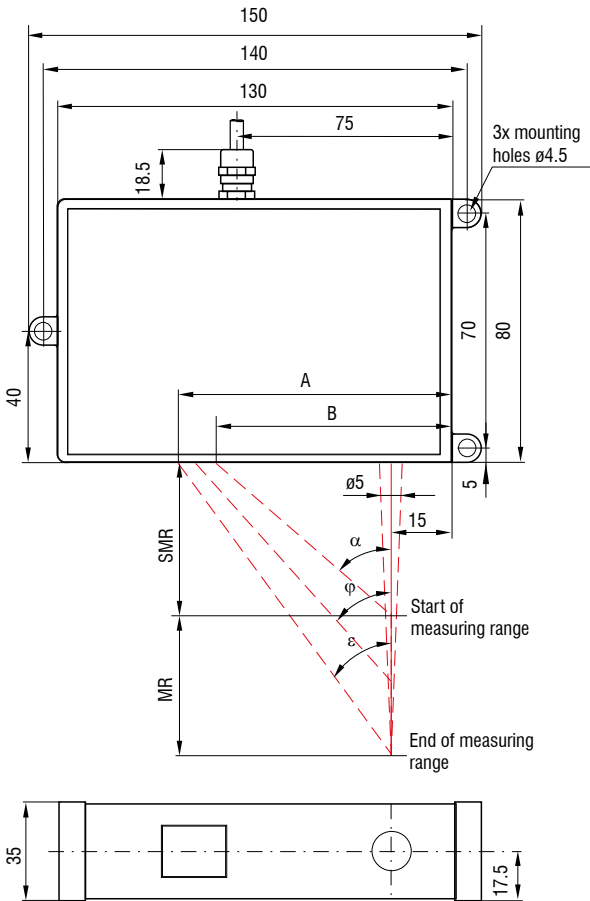

optoNCDT 2300BL / Measuring range 50
optoNCDT 2310 / Measuring range 50

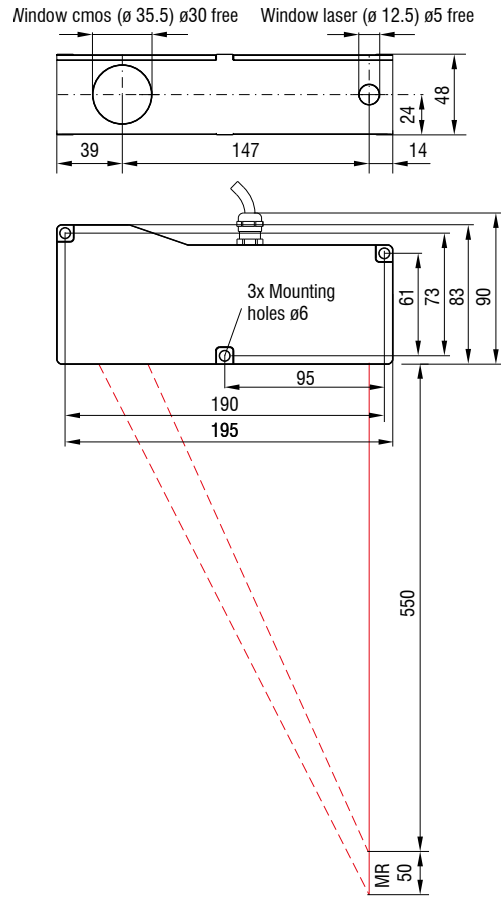

MR	SMR	α	φ	ϵ	A	B
200	130	25.1°	16.7°	13.1°	91.6	76
300	200	18.3°	12.2°	9.6°	99.4	81

(Dimensions in mm, not to scale)

MR = measuring range; SMR = start of measuring range



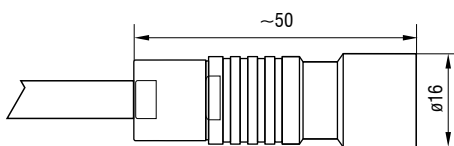

MMR = mid of measuring range; EMR = end of measuring range

Connector (sensor side)



Powerful laser sensors for special applications

optoNCDT 17x0 / optoNCDT 1910

-  Adjustable measuring rate up to 10 kHz
-  **INTERFACE** Analog (U/I) / RS422 / PROFINET / EtherNet/IP
-  **RTSC** Fast surface compensation
-  High repeatability
-  Ideal for large measurement distances

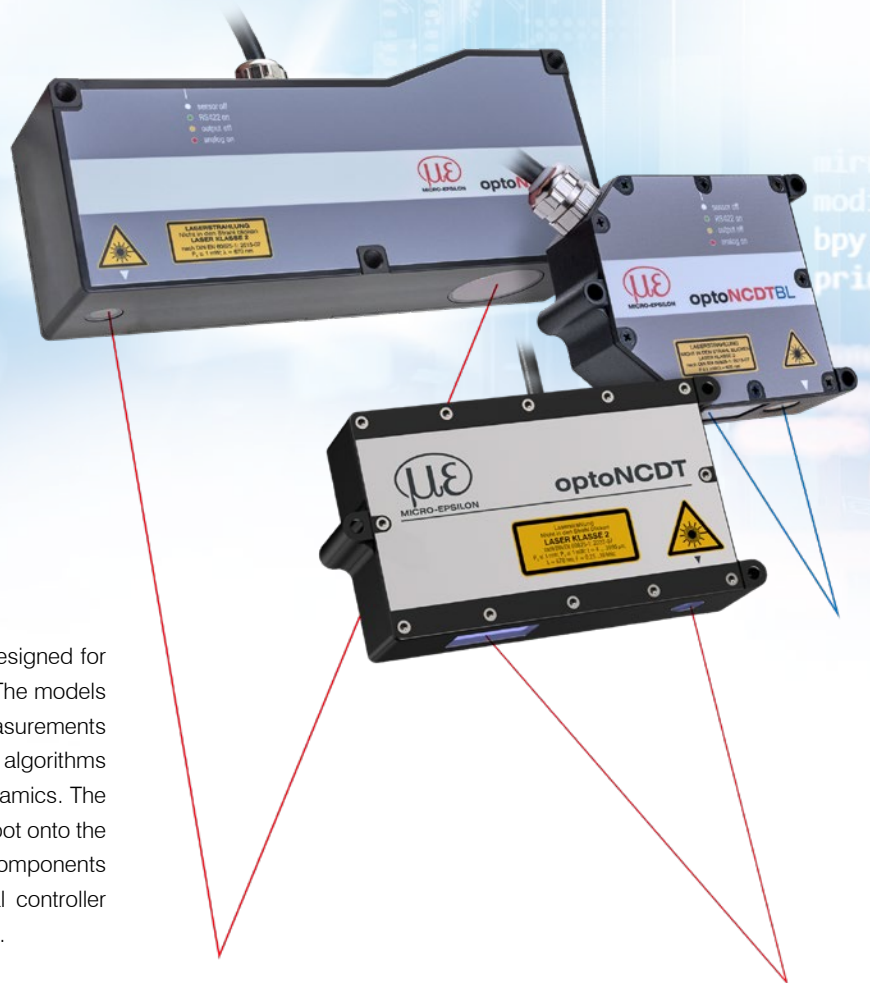





The optoNCDT 1910 and 1750 series laser sensors are designed for fast and precise measurements in industrial applications. The models are used for demanding surfaces and impress in measurements where large distances are required. Innovative evaluation algorithms and improved components enable high accuracy and dynamics. The high-performance optical system generates a small light spot onto the target which enables the detection of even the smallest of components reliably. The pigtail cable in conjunction with the internal controller reduces the installation effort for the sensors to a minimum.

The intelligent exposure control for demanding surfaces

The optoNCDT 1750 sensors feature real-time surface compensation. The real-time surface compensation feature (RTSC) determines the amount of reflection from the target surface during continuous exposure and in real-time. The exposure time or the amount of light produced by the laser is optimally matched to the reflection characteristics of the target surface. This enables extremely reliable measurements even on reflecting surfaces. The optoNCDT 1910 sensors use Advanced Surface Compensation and are also highly resistant to ambient light.

Ideal for industrial applications

Different output signals enable the integration of the sensor into plant and machine control systems. As well as analog voltage and current outputs, a digital interface provides distance information from the sensor. Due to the universal setting and evaluation possibilities, the sensors meet all the requirements for use in industrial applications.

Model	Technology	Measuring range	Repeatability	Linearity
optoNCDT 1750BL		2 - 750 mm	0.8 μm	from 0.06 %
optoNCDT 1750-DR		2 - 20 mm	0.1 μm	0.08 %
optoNCDT 1760		1000 mm	from 7.5 μm	0.10 %
optoNCDT 1910		500 / 750 mm	from 20 μm	0.07 %

Large distance and large measuring range

The optoNCDT long-range models are used to cover a large measuring range or to measure from a large distance to the target. The long-range laser sensors combine high accuracy and large measuring distances.

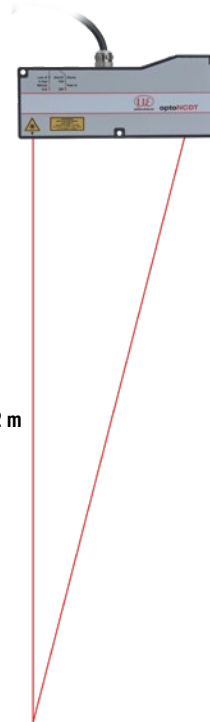

Measurement distances up to 2 m

Application examples



Geometry testing of reflective glass parts

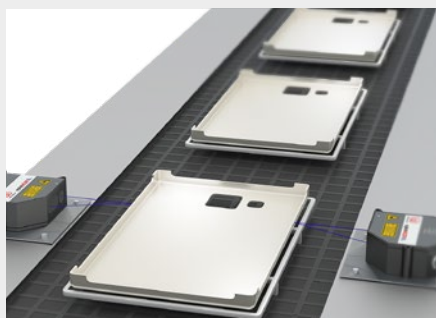

Position check of plastic components

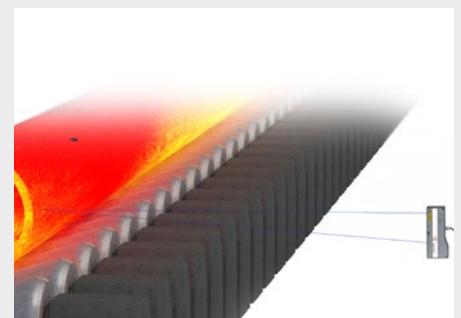

Position measurement of red-hot glowing pipes

Technical data

optoNCDT 17x0 Laser sensors for demanding objects

optoNCDT 1750 (General technical data)

Model	ILD1750-xx	
Measuring rate ^[1]	6 adjustable stages: 7.5 kHz / 5 kHz / 2.5 kHz / 1.25 kHz / 625 Hz / 300 Hz	
Light source	Semiconductor laser < 1 mW, 670 nm (red)	
Laser class	Class 2 in accordance with DIN EN 60825-1: 2022-07	
Permissible ambient light	10,000 lx	
Supply voltage	11 ... 30 VDC	
Power consumption	< 3 W (24 V)	
Signal input	1 x HTL/TTL laser on/off; 1 x HTL/TTL multi-function input: trigger in, slave in, zero setting, mastering, teach-in; 1 x RS422 synchronization input: trigger in, sync in, master/slave, master/slave alternating	
Digital interface ^[2]	RS422 (16 bit) / EtherCAT / PROFINET / EtherNet/IP	
Analog output	4 ... 20 mA / 0 ... 5 V / 0 ... 10 V (16 bit, freely scalable within the measuring range)	
Switching output	2x switching outputs (error & limit value): npn, pnp, push pull	
Connection	integrated pigtail 0.25 m with 14-pin ODU connector, min. bending radius 30 mm when firmly installed; optional extension to 3 m / 10 m possible (see accessories for suitable connection cables)	
Installation	Screw connection via three mounting holes	
Temperature range	Storage	-20 ... +70 °C (non-condensing)
	Operation	0 ... +50 °C (non-condensing)
Shock (DIN EN 60068-2-27)	15 g / 6 ms in 3 axes	
Vibration (DIN EN 60068-2-6)	2 g / 20 ... 500 Hz	
Protection class (DIN EN 60529)	IP65	
Material	Zinc die-cast housing	
Weight	approx. 550 g (incl. pigtail)	
Control and indicator elements ^[3]	Select & function keys: interface selections, mastering (zero), teach, presets, quality slider, frequency selection, factory settings; web interface for setup: application-specific presets, peak selection, video signal, freely selectable averaging possibilities, data reduction, setup management 2 x color LEDs for power / status	

^[1] Factory setting: measuring rate 4 kHz, modifying the factory setting requires the IF2001/USB converter (see accessories)

^[2] EtherCAT, PROFINET and EtherNet/IP require connection via interface module (see accessories)

^[3] Access to web interface requires connection to PC via IF2001/USB (see accessories)



Blue laser - optoNCDT 1750BL

Model		ILD1750-20BL	ILD1750-200BL	ILD1750-500BL	ILD1750-750BL
Measuring range		20 mm	200 mm	500 mm	750 mm
Start of measuring range		40 mm	100 mm	200 mm	200 mm
Mid of measuring range		50 mm	200 mm	450 mm	575 mm
End of measuring range		60 mm	300 mm	700 mm	950 mm
Linearity ^[1]		< ±12 μm	< ±160 μm	< ±350 μm	< ±670 μm
		< ±0.06 % FSO	< ±0.08 % FSO	< ±0.07 % FSO	< ±0.09 % FSO
Repeatability ^[2]		0.8 μm	15 μm	20 μm	45 μm
Light spot diameter ^[3]	SMR	320 μm	1300 μm	1500 μm	1500 μm
	MMR	45 μm			
	EMR	320 μm			
Light source	Semiconductor laser <1 mW, 405 nm (blue violet)				
Material	Die-cast zinc housing			Aluminum housing	

^[1] FSO = Full Scale Output; the specified data apply to white, diffuse reflecting surfaces (Micro-Epsilon reference ceramic for ILD sensors)

^[2] Measuring rate 5 kHz, median 9

^[3] ±10 %; SMR = Start of measuring range; MMR = Mid of measuring range; EMR = End of measuring range



Direct reflection - optoNCDT 1750DR

Model		ILD1750-2DR	ILD1750-10DR	ILD1750-20DR
Measuring range		2 mm	10 mm	20 mm
Start of measuring range		24 mm	30.5 mm	53.5 mm
Mid of measuring range		25 mm	35.5 mm	63.5 mm
End of measuring range		26 mm	40.5 mm	73.5 mm
Linearity ^[1]		< ±1.6 μm	< ±6 μm	< ±12 μm
		< ±0.08 % FSO		
Repeatability ^[2]		0.1 μm	0.4 μm	0.8 μm
Measuring angle		20°	17.6°	11.5°
Light spot diameter ^[3]	SMR	80 μm	110 μm	320 μm
	MMR	35 μm	50 μm	45 μm
	EMR	80 μm	110 μm	320 μm

^[1] FSO = Full Scale Output; the specified data apply to white, diffuse reflecting surfaces (Micro-Epsilon reference ceramic for ILD sensors)

^[2] Measuring rate 5 kHz, median 9

^[3] ±10 %; SMR = Start of measuring range; MMR = Mid of measuring range; EMR = End of measuring range

Technical data

optoNCDT 17x0 Laser sensors for large measuring ranges



Long-Range - optoNCDT 1760

Model		ILD1760-1000
Measuring range		1 000 mm
Start of measuring range		1 000 mm
Mid of measuring range		1 500 mm
End of measuring range		2 000 mm
Measuring rate ^[1]		6 adjustable stages: 7.5 kHz / 5 kHz / 2.5 kHz / 1.25 kHz / 625 Hz / 300 Hz
Linearity ^[2]		< ±1000 µm
		< ±0.1 % FSO
Repeatability ^[3]		100 µm
Light spot diameter ^[4]	SMR	2500 ... 5000 µm
	MMR	
	EMR	
Light source		Semiconductor laser < 1 mW, 670 nm (red)
Laser class		Class 2 in accordance with DIN EN 60825-1: 2022-07
Permissible ambient light		10,000 lx
Supply voltage		11 ... 30 VDC
Max. current consumption		150 mA (24 V)
Signal input		1 x HTL/TTL laser on/off; 1 x HTL/TTL multi-function input: trigger in, slave in, zero setting, mastering, teach-in; 1 x RS422 synchronization input: trigger in, sync in, master/slave, master/slave alternating
Digital interface ^[5]		RS422 (16 bit) / EtherCAT / PROFINET / EtherNet/IP
Analog output		4 ... 20 mA / 0 ... 5 V / 0 ... 10 V (16 bit, freely scalable within the measuring range)
Switching output		2x switching outputs (error & limit value): npn, pnp, push pull
Connection		integrated pigtail 0.25 m with 14-pin ODU connector, min. bending radius 30 mm when firmly installed; optional extension to 3 m / 10 m possible (see accessories for suitable connection cables)
Installation		Screw connection via three mounting holes
Temperature range	Storage	-20 ... +70 °C (non-condensing)
	Operation	0 ... +50 °C (non-condensing)
Shock (DIN EN 60068-2-27)		15 g / 6 ms in 3 axes
Vibration (DIN EN 60068-2-6)		2 g / 20 ... 500 Hz
Protection class (DIN EN 60529)		IP65
Material		Aluminum housing
Weight		approx. 800 g (incl. pigtail)
Control and indicator elements ^[6]		Select & function keys: interface selections, mastering (zero), teach, presets, quality slider, frequency selection, factory settings; web interface for setup: application-specific presets, peak selection, video signal, freely selectable averaging possibilities, data reduction, setup management 2 x color LEDs for power / status

^[1] Factory setting 5 kHz, modifying the factory setting requires the IF2001/USB converter (see accessories)

^[2] FSO = Full Scale Output; the specified data apply to white, diffuse reflecting surfaces (Micro-Epsilon reference ceramic for ILD sensors)

^[3] Measuring rate 5 kHz, median 9

^[4] ±10 %; SMR = Start of measuring range; MMR = Mid of measuring range; EMR = End of measuring range

^[5] EtherCAT, PROFINET and EtherNet/IP require connection via interface module (see accessories)

^[6] Access to web interface requires connection to PC via IF2001/USB (see accessories)

Technical data

optoNCDT 1910 Laser sensors for large measuring ranges



optoNCDT 1910

Model	ILD1910-500	ILD1910-750
Measuring range	500 mm	750 mm
Start of measuring range	200 mm	200 mm
Mid of measuring range	450 mm	575 mm
End of measuring range	700 mm	950 mm
Measuring rate ^[1]	continuously adjustable between 0.25 ... 9.5 kHz or 7 adjustable stages: 9.5 kHz / 8 kHz / 4 kHz / 2 kHz / 1.0 kHz / 500 Hz / 250 Hz	
Linearity ^[2]	< ±0.07 % FSO	±0.08 % FSO
	±350 μm	±600 μm
Repeatability ^[3]	20 μm	30 μm
Light spot diameter ^[4]	800 x 800 μm	1100 x 1100 μm
Light source	Semiconductor laser ≤ 1 mW, 670 nm (red) with laser class 2	
Laser class	Class 2 in accordance with IEC 60825-1: 2014 (Class 3 available on request)	
Permissible ambient light ^[5]	10,000 lx	
Supply voltage	11 ... 30 VDC	
Power consumption	< 3 W (24 V)	
Signal input	1 x HTL/TTL laser on/off; 1 x HTL/TTL multi-function input: trigger in, slave in, zero setting, mastering, teach-in; 1 x RS422 synchronization input: trigger in, sync in, master/slave, master/slave alternating	
Digital interface ^[6]	RS422 (18 bit) / EtherCAT / PROFINET / EtherNet/IP	
Analog output	4 ... 20 mA / 0 ... 5 V / 0 ... 10 V (16 bit, freely scalable within the measuring range)	
Switching output	2x switching outputs (error & limit value): npn, pnp, push pull	
Connection	integrated pigtail 0.3 m with 17-pin M12 plug; optional extension to 3 m / 6 m / 9 m / 15 m possible (suitable connection cable see Accessories)	
Temperature range	Storage	-20 ... +70 °C (non-condensing)
	Operation	0 ... +50 °C (non-condensing)
Shock (DIN EN 60068-2-27)	15 g / 6 ms in 3 axes	
Vibration (DIN EN 60068-2-6)	2 g / 20 ... 500 Hz	
Protection class (DIN EN 60529)	IP65	
Material	Aluminum housing	
Weight	approx. 600 g (incl. pigtail)	
Control and indicator elements ^[7]	Select & function keys: interface selections, mastering (zero), teach, presets, quality slider, frequency selection, factory settings; web interface for setup: application-specific presets, peak selection, video signal, freely selectable averaging possibilities, data reduction, setup management; 2 x color LEDs for power / status	

^[1] Factory setting 4 kHz, median 9, modifying the factory setting requires the IF2001/USB converter (see accessories)

^[2] FSO = Full Scale Output; data related to the digital output and valid for white, diffusely reflecting surfaces (Micro-Epsilon reference ceramic for ILD sensors)

^[3] Typical value with measurements at 4 kHz and median 9

^[4] ± 15 %; light spot diameter determined with point-shaped laser with Gaussian fit (full 1/e² width)

^[5] Illuminant: light bulb

^[6] For EtherCAT, PROFINET and EtherNet/IP, connection via interface module is required (see accessories)

^[7] Access to web interface requires connection to PC via IF2001/USB (see accessories)

Sensors and Systems from Micro-Epsilon



Sensors and systems for displacement, distance and position



Sensors and measurement devices for non-contact temperature measurement



Measuring and inspection systems for metal strips, plastics and rubber



Optical micrometers and fiber optics, measuring and test amplifiers



Color recognition sensors, LED analyzers and inline color spectrometers



3D measurement technology for dimensional testing and surface inspection